

# PHYSICAL MODEL FLUME TESTS OF STORM DRAIN SAFETY GRATES

Prepared for  
Mile High Flood District

By  
Jeff Ellis and Christopher Thornton



Colorado State University

Hydraulics Laboratory  
Daryl B. Simons Building  
Colorado State University  
Fort Collins, Colorado 80521  
November 2023

## 1. Executive Summary

Due to numerous occasions of human injuries and fatalities related to storm drain inlet design and absence of such grates, Mile High Flood District sought out testing to develop improved design criteria for storm drain inlet grates also known as safety grates. Flume testing of storm drain inlet grates occurred at the Colorado State Hydraulics Laboratory from May of 2018 to July of 2023. This report documents the grates tested, human test subject feedback, and data collected to validate a computational fluid dynamics model created in Flow-3D.

Of prime interest was the human test subject feedback to establish a threshold for what configurations of grates and hydraulic conditions were suitable for a human subject to self-rescue. Larimer County Dive Rescue Team volunteered time to serve as test subjects in the maneuvering various grate configurations and flows. This full-scale physical model was compared to a CFD Model performed by AECOM (AECOM, 2024). The main summary of findings are listed below.

- Design threshold of force was found to be 110lbf. When this force is exceeded, a human subject may find it difficult to free themselves from a safety grate.
- A safety grate with a 1:1 (H:V) slope and 12-inch offset was suitable in all tested conditions.
- The CFD model prepared by AECOM corresponded to field data collected in the flume.
- Horizontal bars for steps are not needed.

## Table of Contents

1. Executive Summary .....	2
LISTS OF SYMBOLS, UNITS AND ABBREVIATIONS .....	iii
2. Introduction .....	4
2.1 Background.....	4
2.2 Scope and Objective .....	4
2.3 Testing Facility .....	4
2.4 Flume Configuration.....	5
2.5 Existing MHFD Grate Design Criteria .....	5
2.6 Testing Configurations.....	6
2.6.1 2:1 (H:V) Grate .....	7
2.6.2 1:1 (H:V) Grate .....	8
2.6.3 Vertical Grate.....	9
2.6.4 Concrete Casted Flared End Section Grate.....	10
3. Grate Testing.....	11
3.1 Test Matrix.....	11
3.2 Test 1:.....	12
3.3 Test 2:.....	13
3.4 Test 3:.....	14
3.5 Test 4:.....	15
3.6 Test 5:.....	16
4. Analysis.....	17
4.1 Human Subject Feedback: .....	17
4.2 Velocity.....	17
4.3 Force .....	18
5. Results .....	20
6. Summary .....	21
7. References .....	22
Appendix A.....	23
GRATES.....	23
VELOCITY DATA .....	28

**Figures**

Figure 1. A View of the 20-foot Flume Fitted with a Grate and Wing Walls 5  
Figure 2. Original MHFD 48-inch Diameter Culvert Grate 6  
Figure 3. Configuration 1- MHFD Grate 2:1 (H:V) Slope 7  
Figure 4. Configuration 2- 1:1 (H:V) MHFD Grate 8  
Figure 5. Configuration 3- Vertical Grate 9  
Figure 6. Configuration 4- CCFES Grate 10  
Figure 7. Test 1 (2:1 (H:V) Grate, 48-inch Diameter) 12  
Figure 8. Test 2 (MHFD 1:1 (H:V) Grate, 48-inch Diameter) 13  
Figure 9. Test 3 (Flat Grate Spaced 18-inches, 48-inch Diameter) 14  
Figure 10. Test 4 (CCFES Grate, 30-inch Diameter) 15  
Figure 11. Test 4 (Flat Grate Spaced 0-inches, 30-inch Diameter) 16  
Figure 12. Vertical Grate X-Direction Velocity 18  
Figure 13. Force Testing- Dummy Set Up 19  
Figure 14. Force to Move Dummy Off CCFES Grate 19  
Figure 15. CFD Results of Force 20  
Figure 16. AutoCAD 48-inch 2:1 (H:V) Grate 23  
Figure 17. AutoCAD 48-inch MHFD 1:1 (H:V) Grate 24  
Figure 18. AutoCAD 48-inch Vertical Grate Spaced 18-inches 25  
Figure 19. AutoCAD 30-inch CCFES Grate 26  
Figure 20. AutoCAD 30-inch Vertical Grate 0-inch Spacing 27  
Figure 21. MHFD Velocity Data Collection Locations 28  
Figure 22. Vertical Grate Velocity Data Collection Locations 29

**Tables**

Table 1. 20 Foot Flume Dimensions..... 5  
Table 2. Testing Matrix..... 11  
Table 3. Test 1 Matrix..... 12  
Table 4. Test 2 Matrix..... 13  
Table 5. Test 3 Matrix..... 14  
Table 6. Test 4 Matrix..... 15  
Table 7. Test 5 Matrix..... 16  
Table 8. MHFD Velocity Data 115 cfs..... 30  
Table 9. Vertical Grate Velocity Data 75 cfs..... 31  
Table 10. Vertical Grate Velocity Data 90 cfs..... 32  
Table 11. Vertical Grate Velocity Data 115 cfs..... 33

## LISTS OF SYMBOLS, UNITS AND ABBREVIATIONS

### Symbols

$g$	gravity acceleration on earth
$L$	length
$V$	velocity
$Y$	flow depth
$\nu$	kinematic viscosity of water
$\rho$	density of water

### Units

cfs	cubic feet per second flow rate
ft	foot or feet
ft/s	foot or feet per second
hr, hrs	hour, hours
in	inch(es)
s	second
°F	Fahrenheit degree(s)

### Abbreviations

CSU	Colorado State University
D/S	downstream
ft	feet (as noted above)
g	gage
hr	hour (as noted above)
H:V	ratio of horizontal to vertical step dimensions
s	second (as noted above)
U/S	upstream
MHFD	Mile High Flood District
LCDRT	Larimer County Dive Rescue Team
CCFES	Concrete Casted Flared End Section
CFD	Computational Fluid Dynamics

## **2. Introduction**

### **2.1 Background**

This report presents the results of laboratory tests conducted to assess storm drain inlet grates, and the safety of human interactions on the grates during specified flow conditions. Findings from the tests are of use in designing storm drain inlets, and the associated grates, which are placed over culverts to preventing people and large debris from entering the system. Testing was completed between 2018 and 2023 at CSU's Hydraulics Laboratory, with the help of the Larimer County Dive Rescue Team (LCDRT).

### **2.2 Scope and Objective**

The objective of the hydraulic testing was to enable Mile High Flood District (MHFD) to determine design criteria for culvert grates that provide adequate conveyance while ensuring public safety. Human subjects evaluated the ability to safely egress multiple culvert grates under varying flow depths and velocities. Data were collected in a prototype full scale hydraulic model of a 48 and 30-inch culvert under varying inlet and grate configurations.

Data collected during various tests consisted of point velocity measurements, obtained with an ADV probe, force measurements applied on a safety dummy using a scale, and interviewed results from the LCDRT participants. Verbal results indicated a threshold for what flow conditions were safe and unsafe for each grate. Velocity data were used to verify a computational fluid dynamics (CFD) model completed by AECOM to then extract a force threshold that could be used on a multitude of grates and flow conditions.

### **2.3 Testing Facility**

Flume testing was conducted at the Engineering Research Center's outdoor 180-foot long by 20-foot wide and 8-foot deep flume. Modeled culvert grates were installed at the downstream end of the flume, as illustrated in Figure 1. Flow to the flume was delivered by gravity feed from Horsetooth Reservoir and was measured with an inline Mag meter with associated accuracy of approximately  $\pm 2.0\%$  of the total measured flow rate. The maximum flow rate capacity of the test flume was approximately 150 cfs. Data collection carts spanned the width of the main flume and aprons and were moveable in order to collect data across the flume. Spatial data-collection accuracy was  $\pm 0.01$  ft.



Figure 1. A View of the 20-foot Flume Fitted with a Grate and Wing Walls

## 2.4 Flume Configuration

Flume dimensions are outlined in Table 1. At the exit of the flume, wing walls span diagonally from the orifice to the sides of the flume. This replicates a contraction entering a storm drain inlet. The orifice of the flume was set at 48-inch with a removable 30-inch diameter opening. Variable grates could be installed and bolted to the flume exit wall depending on the test configuration.

Table 1. 20 Foot Flume Dimensions

CSU Hydraulics Lab Outdoor 20-foot Flume	
Width	20 feet
Length	180 feet
Flume Wall Height	8 feet
Min/Max Slope	Approx. 0%
Max Flow Rate	Approx. 200 cfs

## 2.5 Existing MHFD Grate Design Criteria

MHFD's criteria at the time of this study included a 3:1 (horizontal:vertical) or flatter sloped grate with a 9-inch opening at the bottom. Bars of the grate oriented vertically were spaced 5 inches (on center) to allow small debris to pass through while also preventing larger debris from entering and potentially becoming trapped within the culvert. The spacing is also intended to reduce foot entrapment. The criteria specified that a safety grate was required when any of the following conditions were met: when one could not see daylight, conditions could trap or injure, or the culvert was smaller than 42-inch. These criteria



ensured the safety of civilians for culverts smaller than 42-inch but were very costly to construct and took up a large footprint.

Testing in the flume started with a 48-inch culvert and a manufactured grate with a 2:1 slope. A detailed drawing of the original design is shown in Figure 2.

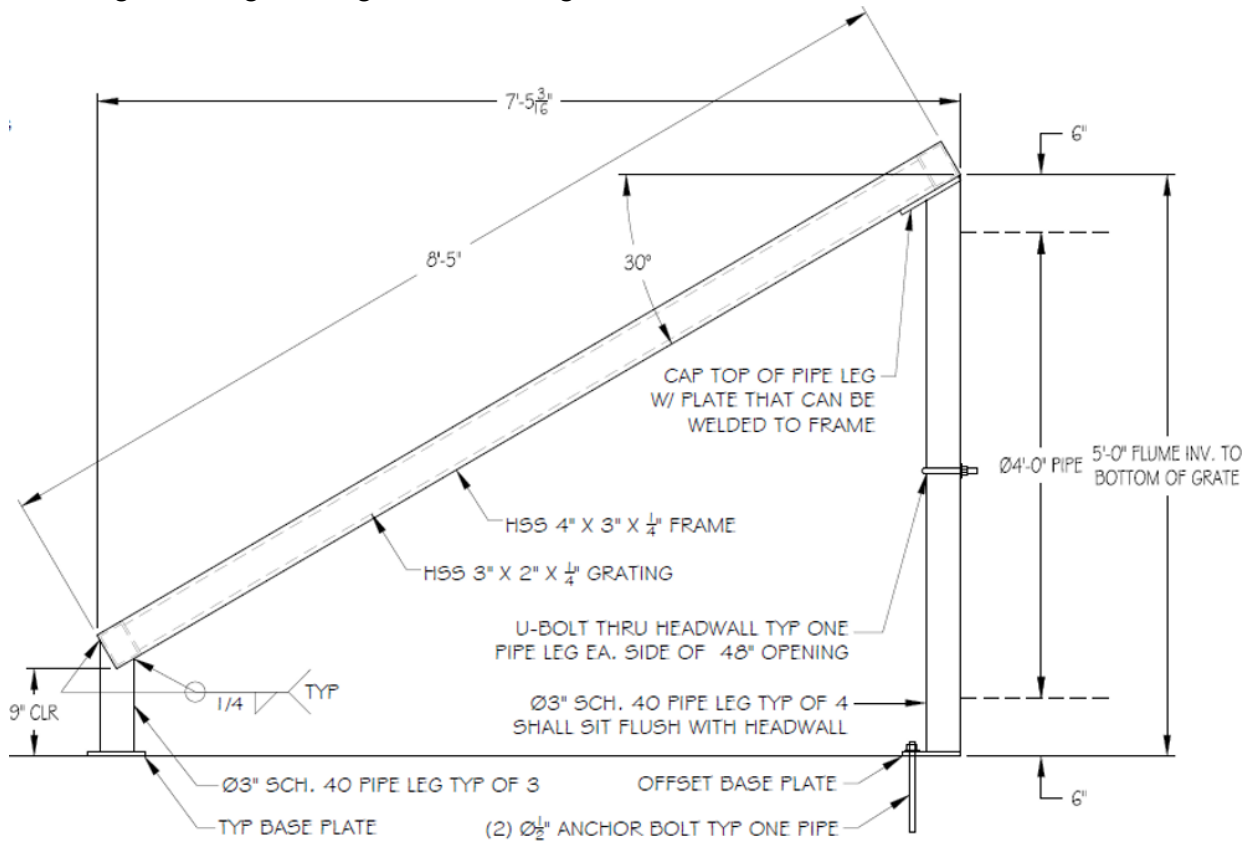

## 2.6 Testing Configurations

Alternative grates for testing were chosen to maximize the efficiency and effectiveness for maintenance, human safety, and overall footprint. Four different grate configurations were chosen to test and are outlined in the following sections. Each grate served a different purpose in order to determine a new design criterion for culvert grates.





### 2.6.1 2:1 (H:V) Grate

To evaluate potential to reduce the footprint of the slope criterion of 3:1 (H:V) or flatter, a 2:1 was first installed for initial testing with the 48-inch opening. The wing walls were built to fit the geometry of the grate and to ensure safety for human test subjects. Figure 3 shows a picture of the installed 2:1 (H:V) MHFD grate.



Figure 3. Configuration 1- MHFD Grate 2:1 (H:V) Slope

### 2.6.2 1:1 (H:V) Grate

To further reduce the footprint of the grate, the 2:1 (H:V) grate was modified to have a new slope of 1:1 (H:V) and spacers of 1-foot on the culvert opening side. Horizontal bars were installed on the left-hand side of the grate behind the vertical bars to evaluate if human test subjects found this beneficial when climbing out of the culvert. A Photo of installation is shown in Figure 4.



Figure 4. Configuration 2- 1:1 (H:V) MHFD Grate with horizontal bars on the left side only



### 2.6.3 Vertical Grate

To determine the limiting conditions for self rescue, a vertical grate was installed in the flume. Adjustable spacers on each corner of the grate were made to change the distance away from the orifice opening ranging from 0 inches away to 18 inches away. The vertical grate was installed for a 48-inch culvert and a 30-inch culvert. Figure 5 shows a picture of the vertical grate installed with 18-inch spacers on the 48-inch culvert.



Figure 5. Configuration 3- Vertical Grate

#### 2.6.4 Concrete Casted Flared End Section Grate

Culvert end sections and grates can also be fabricated by a manufacturer. To assess the safety of these grates, a 30-inch Casted Concrete Flared End Section (CCFES) culvert and associated grate was acquired from a local manufacturer. An associated grate with 5-inch bar spacing was bolted to the top of the CCFES by a hinge connection. A final installation within the flume on a 30-inch-diameter culvert is shown in Figure 6.



Figure 6. Configuration 4- CCFES Grate

### 3. Grate Testing

During the testing, LCDRT had a member of the team in the flume starting 20-feet upstream of the culvert. Floating down stream, the participant would be pulled onto the face of the grate. For each scenario, detailed notes and videos were taken. Important factors included how easy it was to pull straight back off the grate, if the grate forced the participant up and out of the suction velocity field, and how easy it was to climb out. This was repeated for multiple discharges on each grate. When a participant became uncomfortable with the discharge for a configuration, the threshold of discharge and force was set to be the previous discharge tested.

#### 3.1 Test Matrix

Testing took place between May of 2018 and July of 2023. Storm drain inlets sized 30-inch and 48-inch were tested during this period. Various grates were installed to provide key analytical results for design of the MHFD grate. Table 2 lists the configuration of each test.

Table 2. Testing Matrix

Test #	Size (Inches)	Grate Type	Flow Rates (CFS)	Additional Information
1	48	2:1 (H:V)	50-150	Spaced 0" Away from headwall From Inlet
2	48	1:1 (H:V)	75-150	Spaced 12" Away from headwall From Inlet
3	48	Vertical	75-150	Spaced 18" away from headwall From Inlet
4	30	CCFES	25-75	Old Castle Prefabricated
5	30	Vertical	25-35	Spaced 0" away from headwall From Inlet

### 3.2 Test 1:

In May of 2018, the CSU Hydraulics Lab, LCDRT, and MHFD began the initial testing on a 2:1 (H:V) sloped grate spaced 0-inches away from the culvert wall. Figure 7 shows the grate during testing while Table 3 documents the testing matrix. Estimates of discharge were made based on a staff gauge mounted on the wall captured in video footage. Verbal results were documented from the LCDRT members.



Figure 7. Test 1 (2:1 (H:V) Grate, 48-inch Diameter)

Table 3. Test 1 Matrix

Test 1- 2:1 (H:V) Grate (48-inch)			
Run #	Date	Discharge (cfs)	Note
1	5/18/2018	~50	Easy to move and exit flume
2	5/18/2018	~100	Easy to move and exit flume
3	5/18/2018	~150	Easy to move and exit flume



### 3.3 Test 2:

In June of 2021, the MHFD grate at a 1:1 (H:V) slope, spaced 1 foot away from the culvert wall was tested. The 12-inch offset from the wall was included in this configuration based on feedback from the divers that this enabled them a place to help rescue a subject. This also increases the distance between a subject and the orifice where velocities are highest. An action photo of the divers on the grate is provided in Figure 8 along with the testing matrix in Table 4. Verbal results were documented from the LCDRT members and velocity data was collected the proceeding day.



Figure 8. Test 2 (MHFD 1:1 (H:V) Grate, 48-inch Diameter)

Table 4. Test 2 Matrix

Test 2- 1:1 (H:V) MHFD Grate (48-inch)			
Run #	Date	Discharge (cfs)	Note
1	6/23/2021	75	Easy to move and exit flume
2	6/23/2021	90	Easy to move and exit flume
3	6/23/2021	115	Easy to move and exit flume
4	6/23/2021	150	Harder to move, Step bars prevented legs from entering orifice but could get in the way of self-rescue once legs passed the grate.



### 3.4 Test 3:

In July of 2021, a vertical grate spaced 18-inches away from the culvert wall was tested. Figure 9 shows the grate setup during testing while Table 5 documents the testing matrix. Verbal results from the LCDRT were recorded and velocity data was collected.



Figure 9. Test 3 (Flat Grate Spaced 18-inches, 48-inch Diameter)

Table 5. Test 3 Matrix

Test 3- Vertical Grate Spaced 18-inches Away (48-inch)			
Run #	Date	Discharge (cfs)	Note
1	7/16/2021	75	Easy to move and exit flume
2	7/16/2021	90	Diver's legs stuck in grate
3	7/16/2021	115	Divers are stuck to grate
4	7/16/2021	150	Divers submerged, can't move





### 3.5 Test 4:

In July of 2023, a 30-inch prefabricated concrete casted flared end section with the associated grate was tested. Verbal results were recorded, and a test dummy and scale were used to collect force measurements. A testing photograph of the CCFES is provided in Figure 10 along with the testing matrix in Table 6.



Figure 10. Test 4 (CCFES Grate, 30-inch Diameter)

Table 6. Test 4 Matrix

Test 4- CCFES (30-inch)			
Run #	Date	Discharge (cfs)	Note
1	7/9/2023	25	Easy to move and exit, pushed body along grate
2	7/9/2023	50	Easy to move, pushed body along grate
3	7/9/2023	75	Easy to move unless legs enter grate



### 3.6 Test 5:

In July of 2023, a vertical grate spaced 0-inches away from the culvert wall was tested. Testing began at 25 cfs where the LCDRT was easily able to maneuver around. Due to the high forces of this configuration, testing did not proceed past 35 cfs as the LCDRT verbal results were documented. Figure 11 shows the diver pinned against the grate while Table 7 documents the testing matrix.



Figure 11. Test 4 (Flat Grate Spaced 0-inches, 30-inch Diameter)

Table 7. Test 5 Matrix

Test 5- Vertical Grate Spaced 0-inches Away (30-inch)			
Run #	Date	Discharge (cfs)	Note
1	7/9/2023	25	Easy to move, Not Submerged
2	7/9/2023	35	Difficult to move, Legs forced between grate, not comfortable to increase discharge



## 4. Analysis

### 4.1 Human Subject Feedback:

Test 1 included the 2:1 (H:V) grate set up against the 48-inch culvert. This grate was suitable for all flow rates tested. LCDRT had no issues moving along the grate and out of the flume. Based on discussion and verbal results, the 2:1 (H:V) grate was declared to be too large and overbuilt for the design. A grate at a steeper slope would have less of a footprint and could be more efficient.

Test 2 deployed the MHFD grate at a 1:1 (H:V) slope spaced 1 foot away from the 48-inch culvert. On the left half of the grate, horizontal bars behind the vertical bars were also installed to be used as steps for the divers. All flow rates tested were suitable for LCDRT. After positioning bodies multiple ways over the grate, participants always found their way out of the flume. It was never an issue of being stuck on the grate as the angle propelled the divers up and out of the velocity suction field. The installed horizontal bars did not make a drastic difference for the ease of getting away and out of the culvert. One diver commented that the horizontal bars could get in the way of self-rescue. To ease maintenance of the system and prevent smaller debris from getting caught on the system, these will not be recommended in design.

Test 3 evaluated a vertical grate spaced 18 inches away from the 48-inch culvert. Starting at 75 cfs, the culvert was not fully submerged and the LCDRT could easily move around. Approaching 90 cfs, it became difficult to move especially if the legs of the divers were pulled in between the grate bars. Testing continued for 115 cfs and 150 cfs where it was impossible to move away from the grate without help from the safety equipment.

Test 4 investigated a 30-inch precast CCFES with the provided grate. For each flow rate tested, it was easy to move off the grate given the body of the divers were parallel to the fabricated grate. If the legs of a diver were pulled into the grate first, they could become stuck and unable to move. At a flowrate of 75 cfs, a diver required assistance in removing herself from the grate after her legs passed through the surface of the grate. It's important to note that the CFD model assumed that the legs of the person did not pass the surface of the grate.

Test 5 assessed a vertical grate spaced 0 inches away from the 30-inch culvert. Starting at 25 cfs, it was uncomfortable for the divers, but it was still easy to move as the culvert was not fully submerged. Increasing to 35 cfs, it was very uncomfortable for LCDRT, and they could not remove themselves away from the culvert and off the grate. Due to the safety of the team, the team decided not continue with higher flow rates.

### 4.2 Velocity

Once verbal results were taken from LCDRT, velocity data was collected the following day. Data were collected normal to the grate surfaces every foot along the plane. Velocity data were collected and analyzed to calibrate the CFD model. Points were taken for test configurations 2 and 3. After validating the velocity profiles via the CFD model (AECOM, 2023), additional data were not collected for tests 4 and 5. An example of the results is shown in Figure 7 while additional tables of results are provided in the

appendix. Once the CFD was calibrated to match the physical model, variables were extracted to determine a force threshold corresponding to a depth and discharge for each grate on a body.

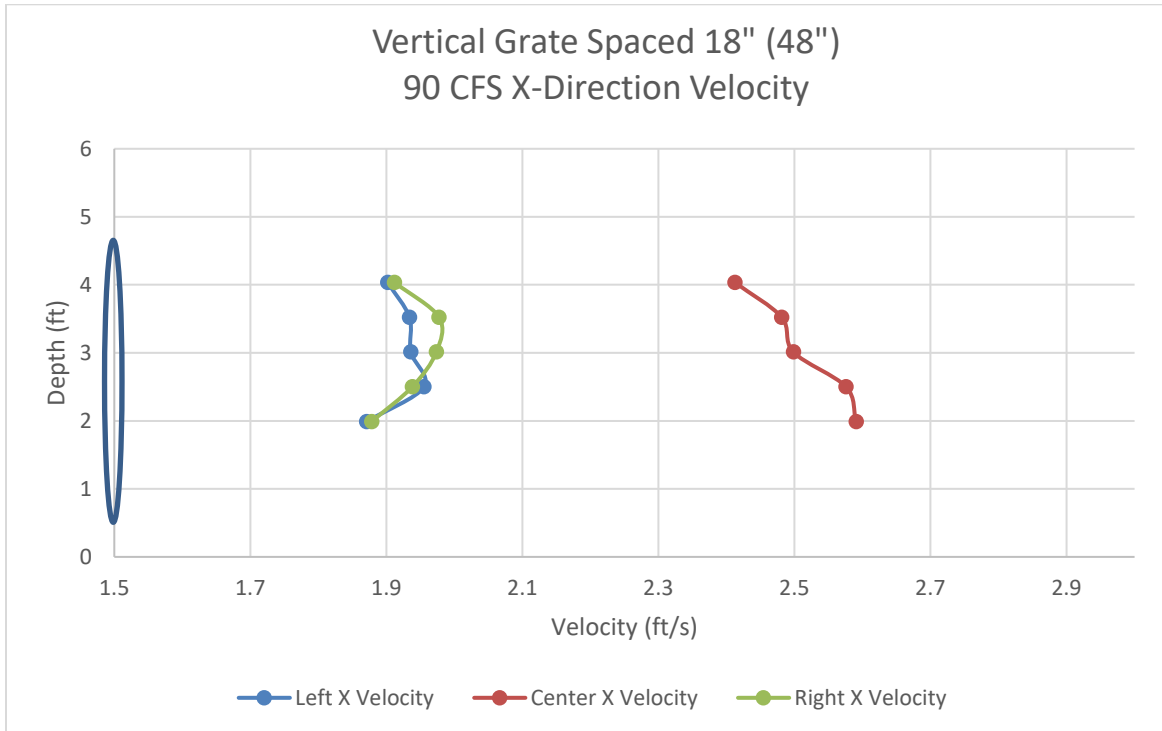

Figure 12. Vertical Grate X-Direction Velocity

### 4.3 Force

Additional data were collected with a safety dummy and scale to validate the force measurements extracted from the CFD model. To ensure safety of the LCDRT, a dummy was used for testing. The dimensions of the dummy were similar to a small adult standing 5'8", but only weighed about 75lb. Due to the buoyancy on the dummy, the feet and hands were loosely tied to the culvert grate. A harness was placed on the dummy along with a rope spanning to the data cart of the flume. Using a scale, the dummy was pulled with the rope normal to the grate and the force was recorded for the initial pull to displace the dummy along with the force to hold the dummy 1" away from the grate. Results were consistently about 20 lb less than the CFD model. This may be due to the size difference and buoyancy of the dummy. Overall, the results of the physical model followed similar trends of the CFD and would be closer with a replicable dummy at 6-foot tall, as was used in the CFD. Figure 8 displays the dummy on the grate being pulled normal to the surface while Figure 9 shows the results of force testing.



Figure 13. Force Testing- Dummy Set Up

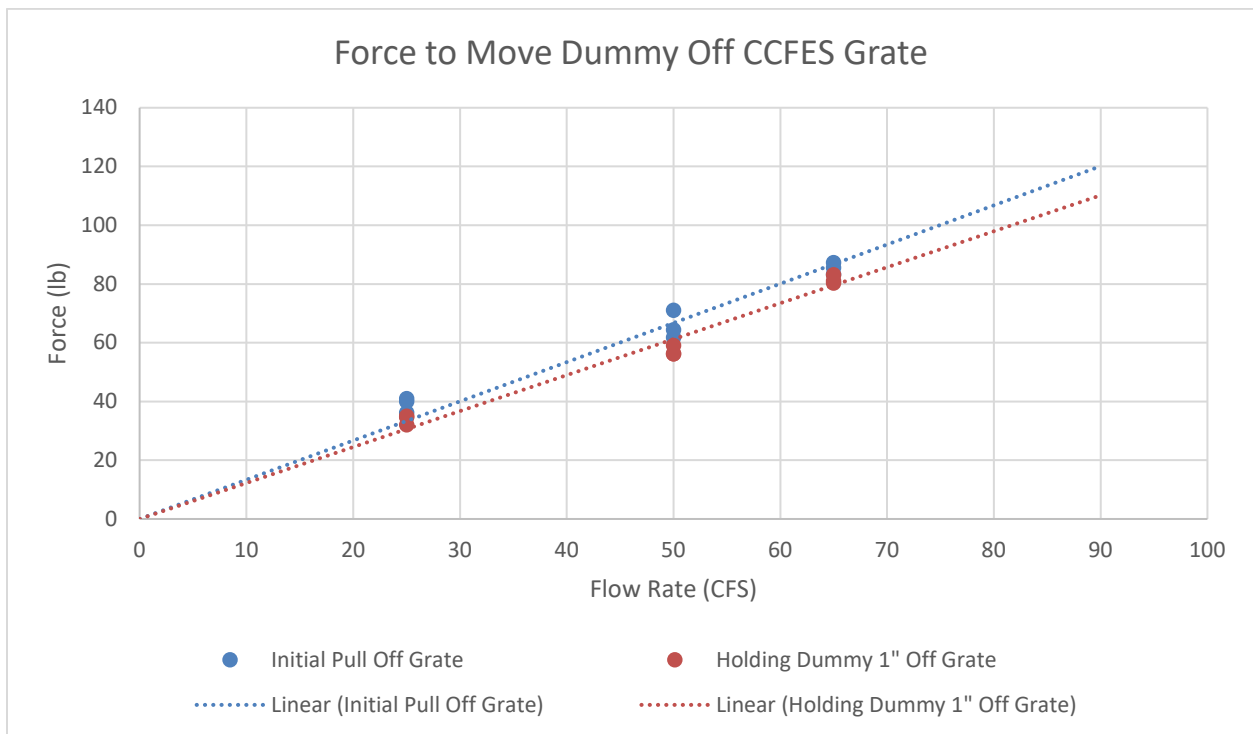

Figure 14. Force to Move Dummy Off CCFES Grate

## 5. Results

The final conclusions of the test were all extracted from the CFD Model created using Flow-3D. It was found that the design threshold of force on a body should not exceed 110 lbf. Using verbal results from Test 3, the vertical grate spaced 18" away from the pipe orifice, the threshold was right above 75 cfs, with a force of 107.5 lbf. At this flow rate, the divers could easily move off the grate and get out of the flume. Increasing the discharge to 90 cfs, the LCDRT struggled to move as limbs were sucked into the orifice at a force of 142.2 lbf. Using these criteria, every configuration was plotted to show the flow conditions and grate type vs force. If the force exceeds 110 lbf for a certain condition, the type of grate should be changed. Test 1 took up too large of a footprint and was not considered for testing on the CFD model. Test 2, the MHFD grate at a 1:1 slope, was below the threshold and had a smaller footprint than the grate with a 2:1 slope. At a flowrate of 75 cfs, test 4, was well above the threshold force of 110 lbf in the CFD model. After testing in the physical model, the team confirmed that the diver required an assist to remove herself from the grate. With a vertical grate and no offset from the orifice of the pipe, test 5 followed the trends of the CFD being intolerable for flows over 25cfs. Figure 10 graphically summarizes the results of the CFD model.

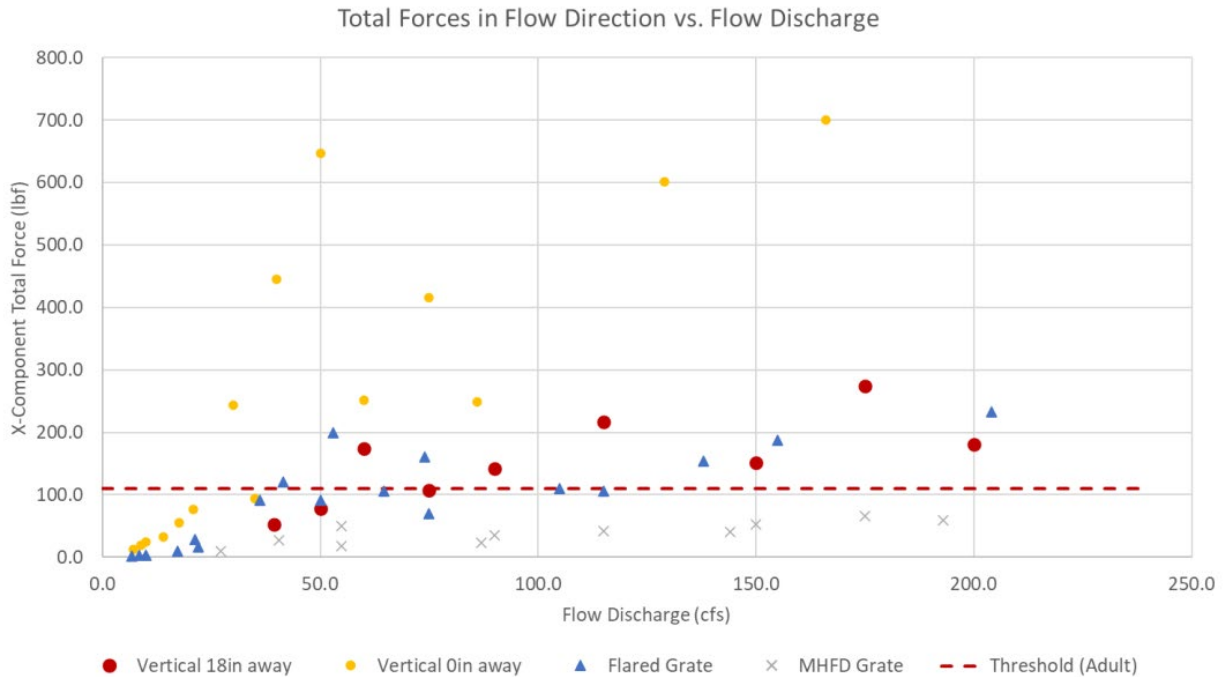

Figure 15. CFD Results of Force

## 6. Summary

Flume testing from May of 2018 to July of 2023 was conducted on storm drain inlet grates by Colorado State University. Testing was performed at the Hydraulics Laboratory located at the Engineering Research Center at prototype scale. Descriptions of the grates tested, human interactions, data collection, and resulting database are presented in this report. Five grate configuration tests were run with increasing discharges and multiple LCDRT personnel. Testing continued until the design discharge was reached, or the human test subjects felt uncomfortable to proceed with higher discharges.

Recommendations from the testing results are as follows:

- Design threshold of force was found to be 110lbf. When this force is exceeded, a human subject may find it difficult to free themselves from a safety grate.
- A safety grate with a 1:1 (H:V) slope and 12-inch offset was suitable in all tested conditions.
- The CFD model prepared by AECOM corresponded to field data collected in the flume.
- Horizontal bars for steps are not needed.



## 7. References

AECOM (2024) *Storm Drain Safety Grates: Computational Fluid Dynamics Modeling Report*. Available at [www.mhfd.org](http://www.mhfd.org).





Appendix A

GRATES

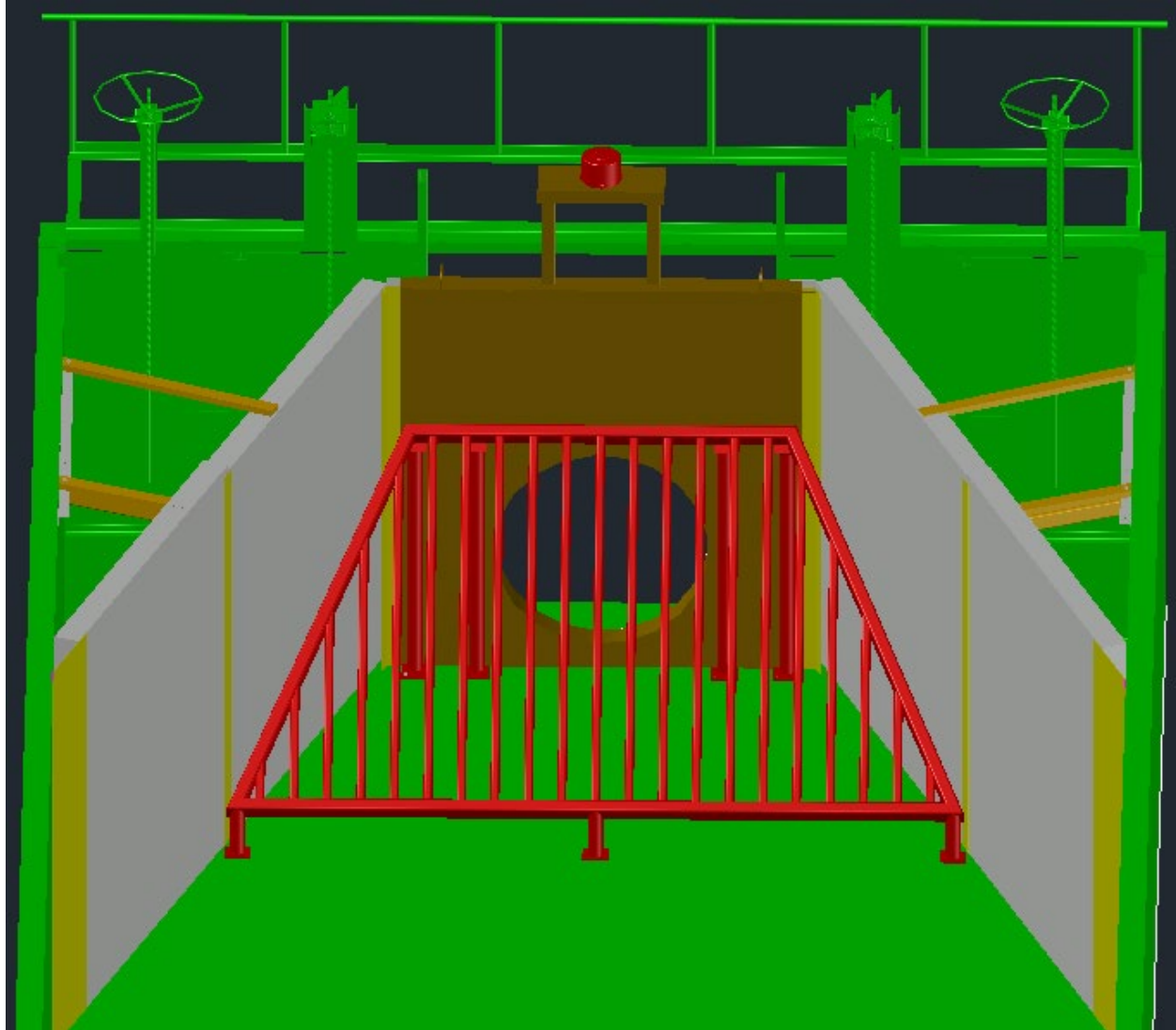

Figure 16. AutoCAD 48-inch 2:1 (H:V) Grate

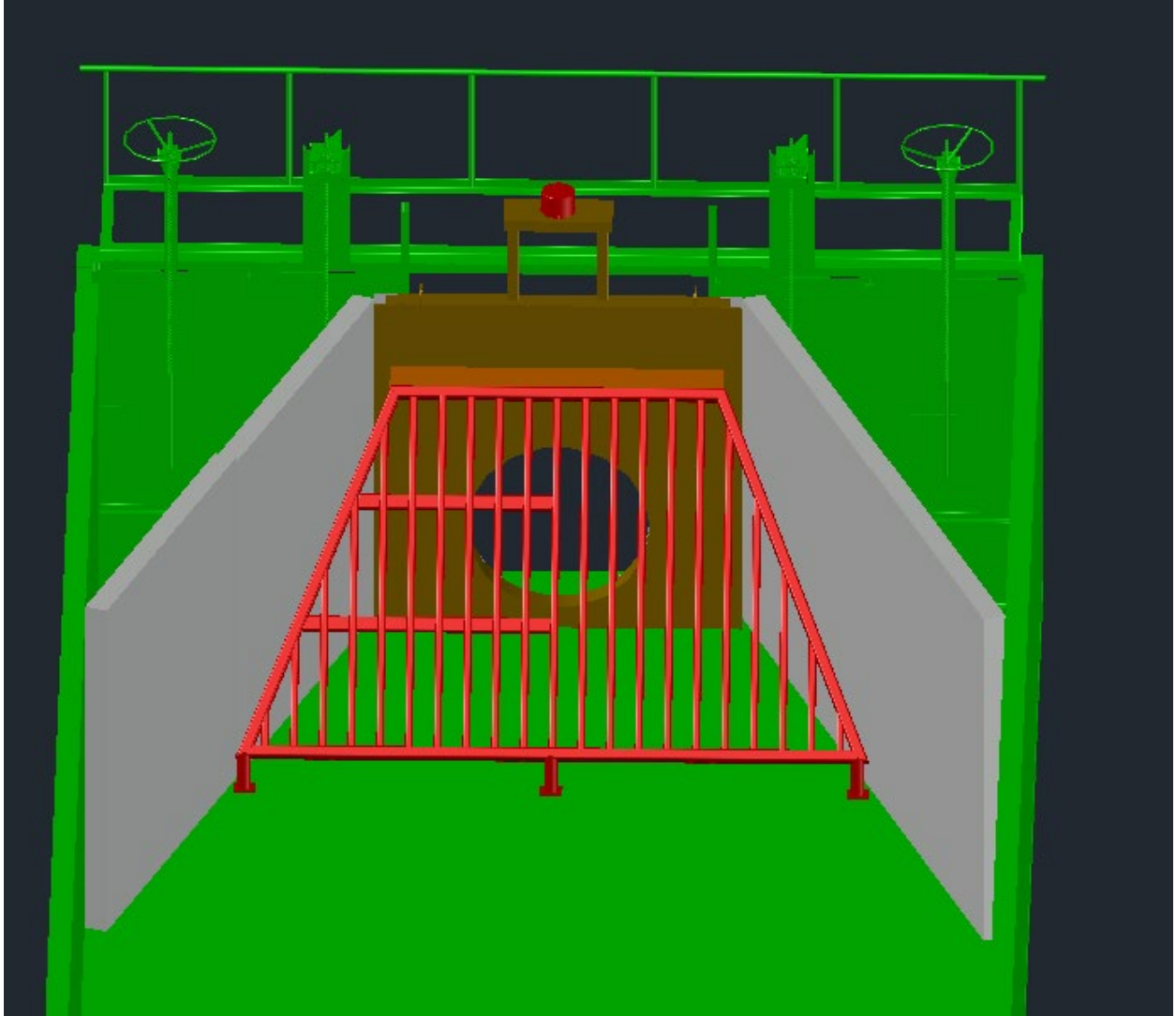

Figure 17. AutoCAD 48-inch MHFD 1:1 (H:V) Grate



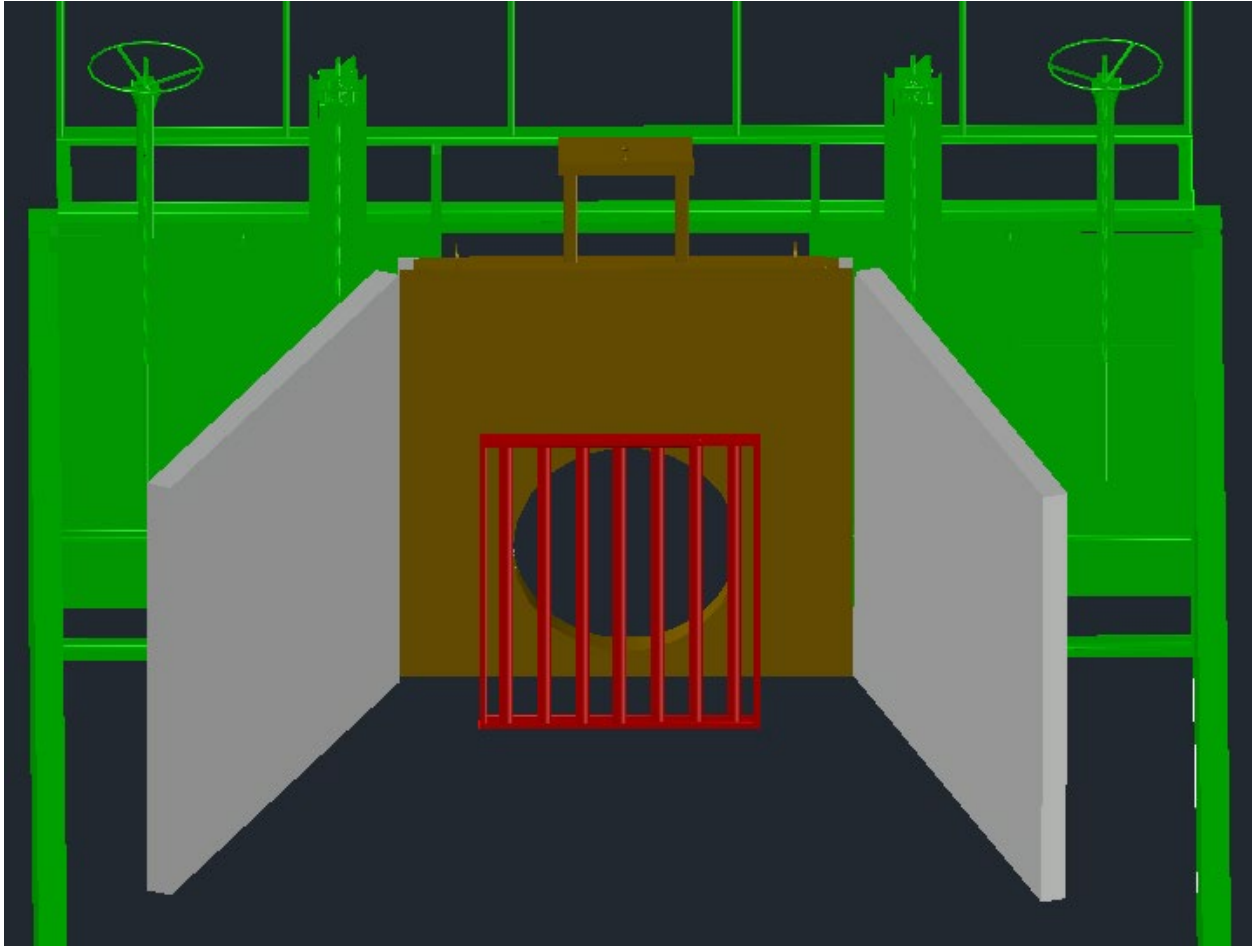

Figure 18. AutoCAD 48-inch Vertical Grate Spaced 18-inches



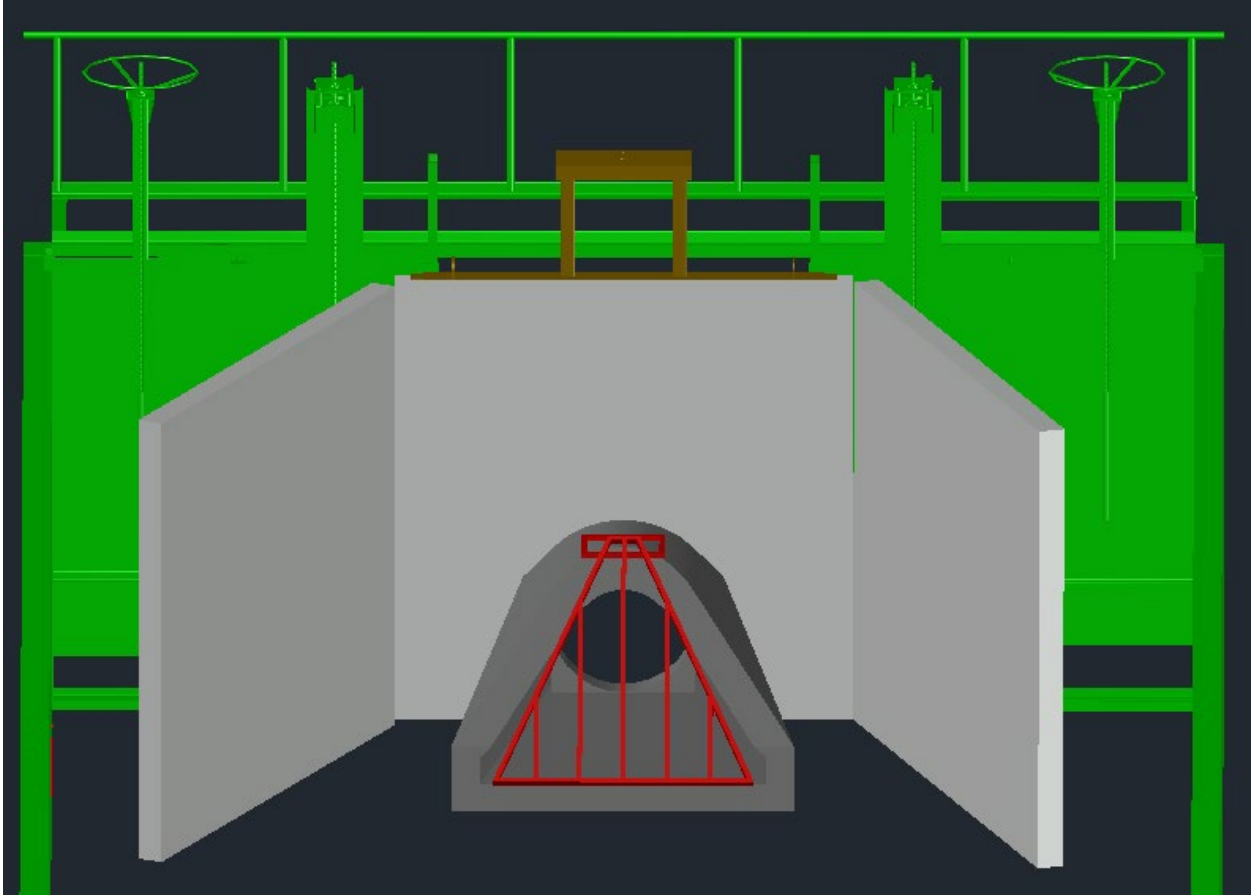

Figure 19. AutoCAD 30-inch CCFES Grate

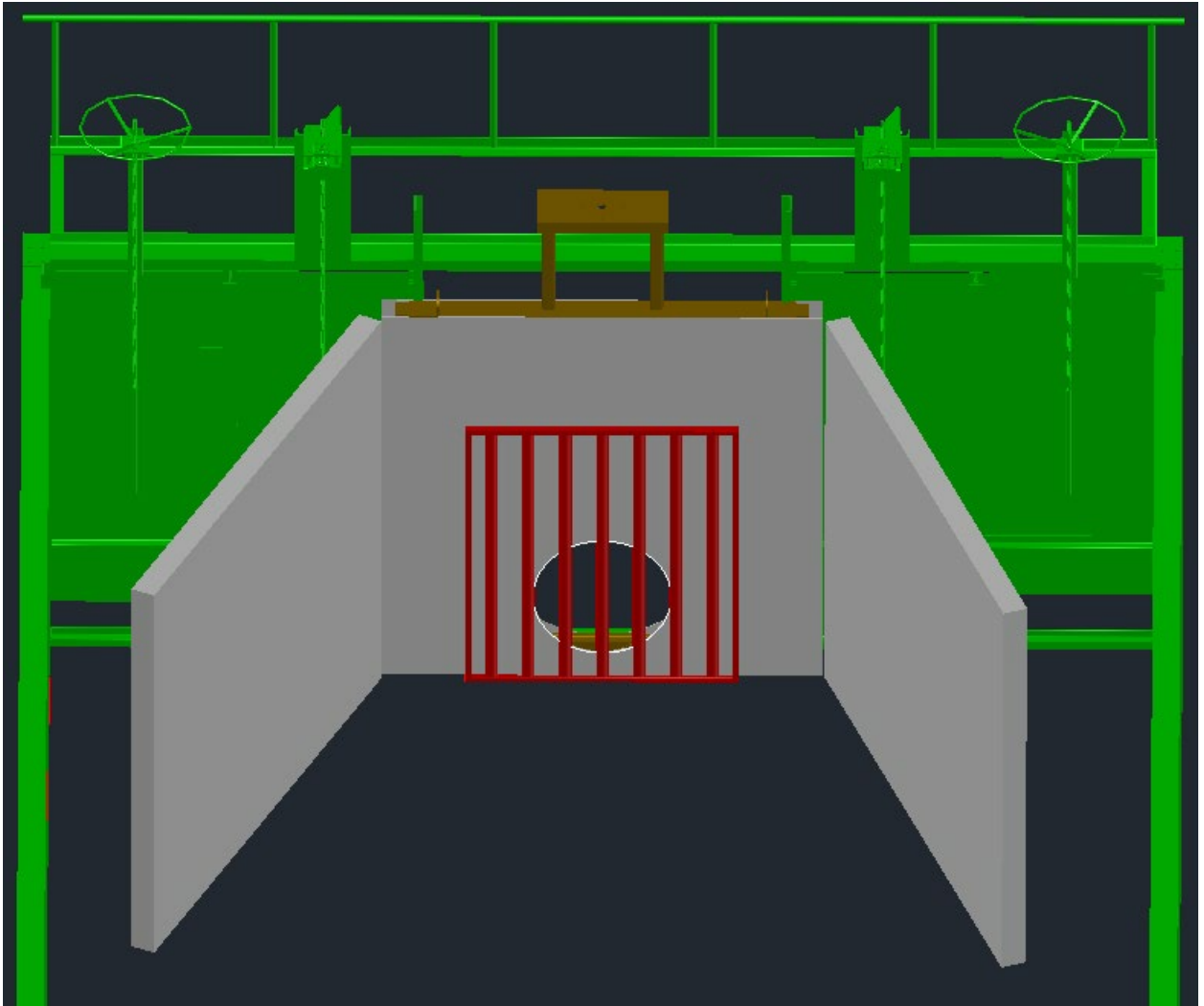

Figure 20. AutoCAD 30-inch Vertical Grate 0-inch Spacing



## VELOCITY DATA

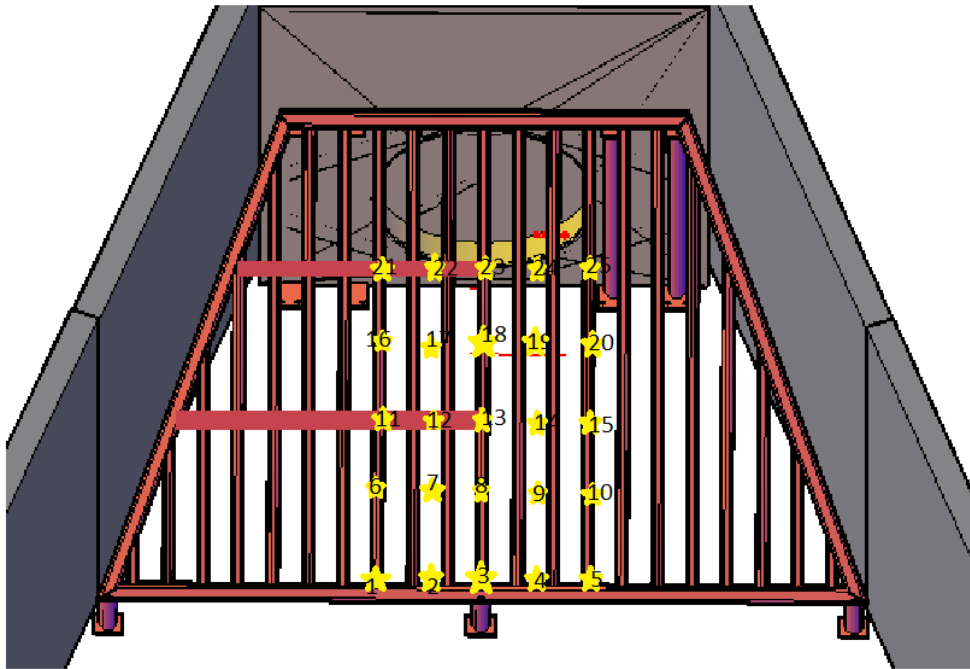

Figure 21. MHFD Velocity Data Collection Locations

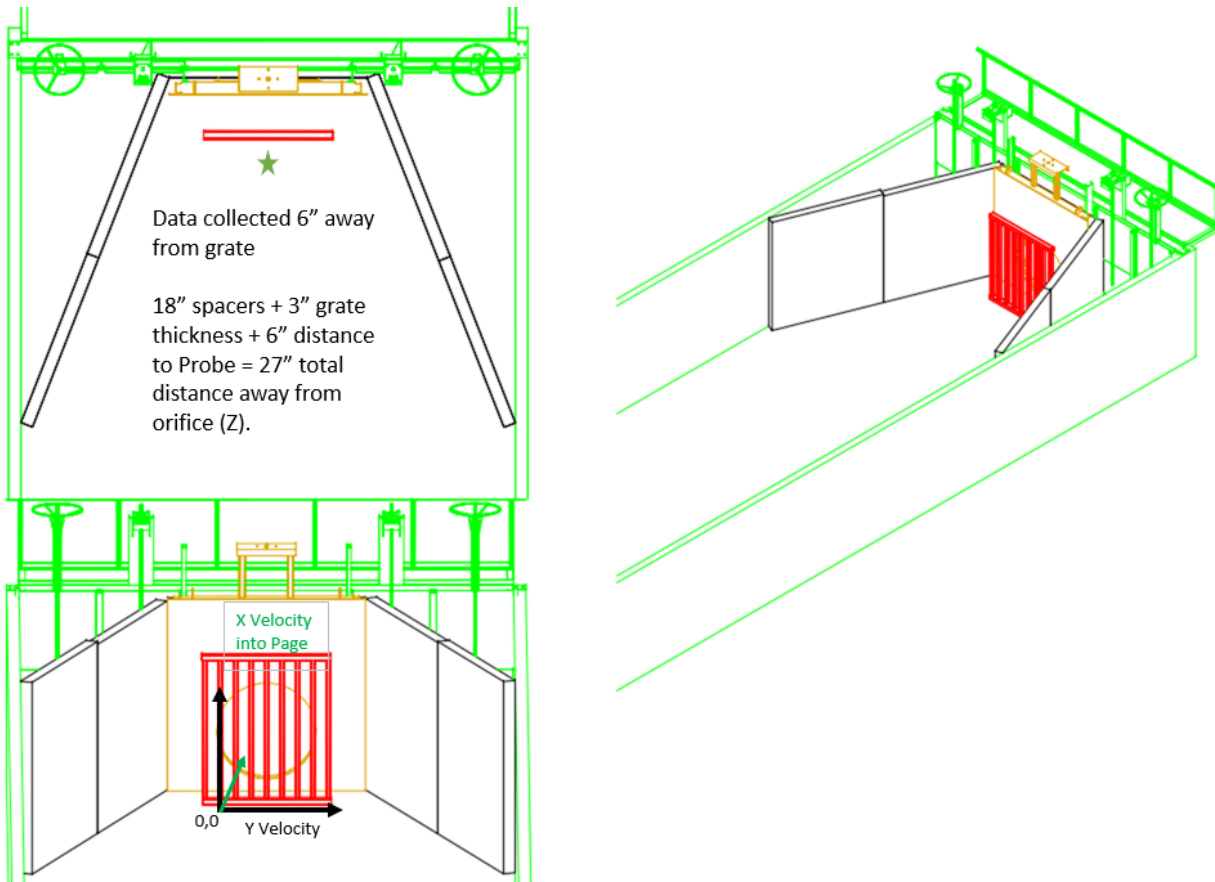

Figure 22. Vertical Gate Velocity Data Collection Locations



Table 8. MHFD Velocity Data 115 cfs

flume location (ft)		Location Relative to Orifice (left to right) (ft)				
		0	1	2	3	4
100.1	point	1	2	3	4	5
	%Good	72.52	73.51	63.12	82.45	64.9
	V X(ft/s)	1.565608	1.660185	1.652148	1.864901	1.710926
	V Y(ft/s)	-0.20046	-0.10335	-0.18057	0.16084	0.045597
	V Z1(ft/s)	0.093983	-0.04236	0.077575	-0.16723	-0.1162
	V Z2(ft/s)	0.108386	-0.02767	0.097947	-0.14813	-0.10098
	V Mag.(ft/s)	1.581185	1.663938	1.663795	1.87928	1.715474
101.1	point	6	7	8	9	10
	%Good	78.41	78.81	77.41	76.49	74.42
	V X(ft/s)	1.494223	1.518521	1.586171	1.702692	1.644853
	V Y(ft/s)	-0.15723	-0.10952	-0.12362	0.077076	0.250813
	V Z1(ft/s)	-0.04837	-0.02701	0.021752	-0.14124	-0.1404
	V Z2(ft/s)	-0.03551	-0.01061	0.042564	-0.12619	-0.13056
	V Mag.(ft/s)	1.503251	1.522705	1.591129	1.710278	1.669779
102.1	point	11	12	13	14	15
	%Good	79.47	71.85	73.42	74.09	73.75
	V X(ft/s)	1.580045	1.679366	1.699973	1.699935	1.6874
	V Y(ft/s)	-0.31451	-0.12598	-0.01944	0.080801	0.311021
	V Z1(ft/s)	0.011924	-0.02908	-0.03785	0.024846	-0.10687
	V Z2(ft/s)	0.028748	-0.01334	-0.02175	0.039948	-0.10392
	V Mag.(ft/s)	1.611087	1.684337	1.700505	1.702036	1.719149
103.1	point	16	17	18	19	20
	%Good	76.16	75.08	70.2	76.74	84.72
	V X(ft/s)	1.558513	1.74482	1.763054	1.840606	1.705974
	V Y(ft/s)	-0.26232	-0.27965	-0.2471	0.082464	0.281742
	V Z1(ft/s)	-0.11707	-0.07941	-0.11044	-0.1428	-0.11792
	V Z2(ft/s)	-0.09661	-0.06267	-0.0905	-0.12424	-0.10378
	V Mag.(ft/s)	1.584766	1.768871	1.783708	1.847978	1.733099
104.1	point	21	22	23	24	25
	%Good	74.17	80.07	87.71	85.38	77.74
	V X(ft/s)	1.751957	1.775173	1.847736	1.991486	1.805077
	V Y(ft/s)	-0.35873	-0.28351	-0.27786	0.093971	0.34279
	V Z1(ft/s)	0.132766	0.078763	0.032178	-0.19473	-0.06045
	V Z2(ft/s)	0.151124	0.093644	0.049562	-0.17366	-0.04129
	V Mag.(ft/s)	1.793228	1.799394	1.868788	2.003189	1.838331





Table 9. Vertical Grate Velocity Data 75 cfs

<b>75 CFS</b>					
Velocity Magnitude(ft/s)					
depth(Z)	0'	1'	2'	3'	4'
4.035	2.057084799	2.220087051	2.303538799	2.100996017	1.823188305
3.523	2.010002136	2.273125648	2.255692482	2.275829554	1.932112813
3.012	2.031548262	2.278100491	2.266544342	2.216678143	1.909257531
2.5	2.052156687	2.268302917	2.327448606	2.222443342	1.958427906
1.989	1.892451882	2.337479591	2.322765827	2.249081135	1.875541449
Velocity X Direction (ft/s)					
depth(Z)	0'	1'	2'	3'	4'
4.035	1.846495748	2.114216805	2.280283928	2.092329025	1.7499578
3.523	1.78342104	2.152406454	2.243763685	2.264811516	1.838127494
3.012	1.79595983	2.186017752	2.244084358	2.209897757	1.79529953
2.5	1.773258448	2.157186985	2.311658382	2.20522666	1.822734237
1.989	1.629223704	2.23590064	2.307486057	2.233119488	1.73365593
Velocity Y Direction (ft/s)					
depth(Z)	0'	1'	2'	3'	4'
4.035	-0.90119177	-0.66910279	-0.30331036	0.158349782	0.504042089
3.523	-0.92626387	-0.72866791	-0.21589392	0.206000671	0.58054781
3.012	-0.94910192	-0.64050961	-0.31758544	0.160629407	0.645483077
2.5	-1.0324651	-0.69946754	-0.2663168	0.275654078	0.707557738
1.989	-0.9453029	-0.67661619	-0.25287768	0.267464966	0.711130202



Table 10. Vertical Grate Velocity Data 90 cfs

<b>90 CFS</b>					
Velocity Magnitude(ft/s)					
depth(Z)	0'	1'	2'	3'	4'
4.035	2.15785861	2.427451611	2.444292307	2.383894682	2.027808189
3.523	2.27197504	2.413803816	2.505660057	2.423687696	2.108897686
3.012	2.251606703	2.568909168	2.515775442	2.431680918	2.132962227
2.5	2.284931183	2.587860346	2.594572067	2.483008	2.108521938
1.989	2.297774553	2.673756123	2.610104799	2.397337437	2.091923952
Velocity X Direction (ft/s)					
depth(Z)	0'	1'	2'	3'	4'
4.035	1.901888609	2.312032223	2.412410736	2.367077827	1.912023544
3.523	1.933937311	2.319948912	2.481098175	2.417109251	1.977367759
3.012	1.935848594	2.458019018	2.498355627	2.419677258	1.973541141
2.5	1.955211043	2.462053061	2.575819254	2.473894	1.938083887
1.989	1.871015549	2.562088966	2.590485573	2.375972986	1.878212929
Velocity Y Direction (ft/s)					
depth(Z)	0'	1'	2'	3'	4'
4.035	-1.01624072	-0.72493845	-0.37705341	0.234737456	0.659248173
3.523	-1.18631685	-0.66654754	-0.33881375	0.147984684	0.709364891
3.012	-1.14953256	-0.73286051	-0.29540396	0.239890173	0.804155886
2.5	-1.18231869	-0.79706138	-0.31137225	0.204182	0.823928952
1.989	-1.33356798	-0.76419514	-0.30577257	0.313442975	0.919508994



Table 11. Vertical Grate Velocity Data 115 cfs

<b>115 CFS</b>					
Velocity Magnitude(ft/s)					
depth(Z)	0'	1'	2'	3'	4'
4.896	2.082574606	2.25827527	2.255302429	2.351815939	2.071828842
4.097	2.346806526	2.596737862	1.647562265	2.594514132	2.256392002
3.299	2.514542341	2.759242058	1.68774569	2.716680527	2.351864815
2.5	2.240748882	2.486706018	2.79737711	2.51915741	2.549590588
2.046	2.300688028	2.528379917	2.565299988	2.157041788	2.160077095
Velocity X Direction (ft/s)					
depth(Z)	0'	1'	2'	3'	4'
4.896	1.887818098	2.148053169	2.224226475	2.313791513	1.91184175
4.097	2.018797159	2.442944288	1.613740444	2.562218428	2.076478481
3.299	2.105305433	2.625241041	1.625443459	2.694003344	2.149381876
2.5	1.943726897	2.353013515	2.761101723	2.516748667	2.288367271
2.046	1.92564714	2.368999243	2.558627367	2.148174763	2.025134802
Velocity Y Direction (ft/s)					
depth(Z)	0'	1'	2'	3'	4'
4.896	-0.86262333	-0.65593451	-0.28929397	0.1511814	0.721151054
4.097	-1.17014074	-0.80658084	-0.31466329	0.235726193	0.813511074
3.299	-1.35007751	-0.82825959	-0.45409074	0.285157442	0.91116935
2.5	-1.11459696	-0.80260855	-0.44723442	0.110013627	1.092525244
2.046	-1.258479	-0.87279719	-0.14720233	0.176396951	0.751398683

